

# *Gladding, McBean*

## LINCOLN INTERLOCKING ROOF TILE

*Kiln-Run #8 Mix*

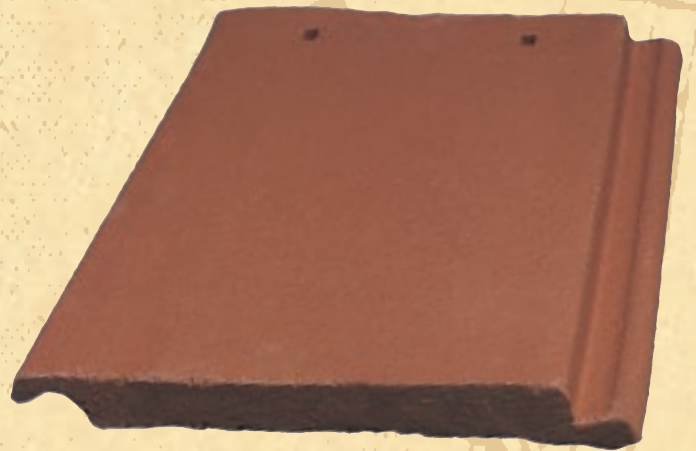

*Blended Red*



*Spanish Bay Blend*

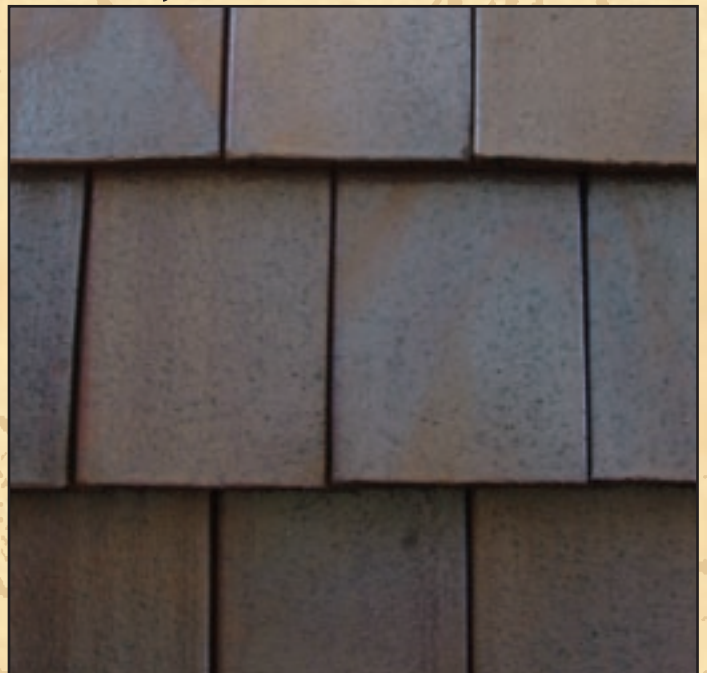

# LINCOLN INTERLOCKING CLAY ROOF TILE

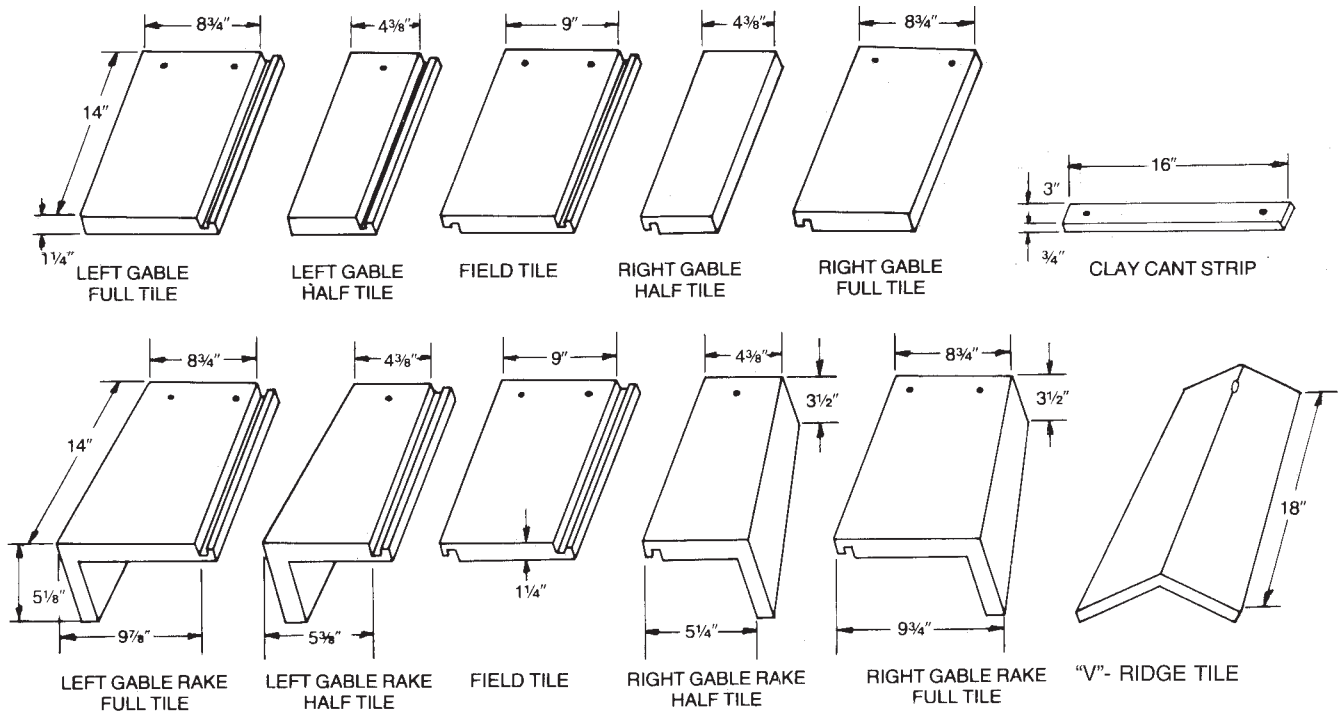

## SPECIFICATIONS

### A. MATERIALS

- There are 145 pieces of field tile per square weighing approximately 900 pounds.
- Roofing tile shall be Gladding, McBean Lincoln Interlocking Clay Tile 14" long to 9" wide, square butt, and laid with an exposure of 11". Meeting requirements of ASTM C-1167.
- Under eave shall be (specify one):
  - Clay tile cant strip 3" x 16" x 3/4".
  - 14" long clay cant strip with integral overhanging eave apron.
  - 1" x 2" wood cant strip.
- Hips and ridges shall be "V" type clay tile 18" long laid with an exposure of 14". (Specify pitch of roof.)
- Gable trim shall be (specify one):
  - Plain gable interlocking tile.
  - Overhanging gable interlocking rake tile.
- Cement Mortar: The mortar used under the hip, ridge and gable tile shall be Type M by proportions per U.B.C. Table 21A. This mix is basically (by volume) 1 part Type I cement (or masonry cement) to 3 parts damp plaster sand.

### B. COLOR shall be (specify one):

- Kiln-run No. 8 Mix.
- Blended Red.
- Spanish Bay.

**C. UNDERLAY**—The underlayments described are very conventional and in accordance with many building code requirements including I.C.B.O. Uniform Building Code and the City of Los Angeles Building Code. Sweep roof surface broom clean. Cover knot holes with tin. Specify desired weight of underlay as follows:

#### For Pitches of less than 4/12:

- Lay two layers of 30# felt at right angles to roof surface, nail to secure in place as code requires. Mop solidly 25# per square between layers and on top of layers with hot asphalt.

#### For Pitches of 4/12 and greater:

- Lay one layer of 30# or 40# felt. Lay with 4" head lap and a 6" side lap. Nail to secure in place as code requires.

### D. TILE FASTENERS

—Tile shall be fastened by

(specify one of the following):

- Nails—Noncorrosive. Sufficient length shall give 3/4" penetration. (Consult manufacturer of special roof deck materials for additional nailing specifications.)
- Fasteners—To be installed per project specifications using applicable 300 series Stainless Steel or Galvanized Tyle Tye Systems, as manufactured by Newport Fasteners, per I.C.B.O. 3362 and provided by Gladding, McBean. Consult factory regarding applicable deck attachment and accessories.

### E. METHOD OF APPLICATION:

- Alternate rows shall be started at gable with half width gable trim.
- All hip, ridge, gable and first row of cover tiles after gable roll shall be set in cement mortar and fastened with noncorrosive nails. Refer to "Clay Roof Tile Specifications and Suggested Installation Details" showing desired construction of hips, ridges and gable rakes.
- All tile in contact with cement mortar shall be immersed in water for at least 2 minutes before laying to avoid drying out the mortar before setting and curing.

**Shade Blending:** After 75 to 100 tiles are installed, examine the application at a distance from ground level for straight, true lines and good color blend. This should be done at regular intervals during installation to insure an attractive and acceptable roof. Blending of shade is particularly important to avoid streaks or hot spots." Acceptable blending cannot be done at the factory or on the ground; it can only be done as the tile is applied.

G111b 2,500 CP 08/14/06